

DOUBLEREK 



DOUBLEREK SYSTEM

Reliable shouldering applications with superior accuracy

nikkoTOOLS

DOUBLEREK

| | | | | | |
|---|---|---|---|---|---|
| P | M | K | N | S | H |
| H | I | H | | I | |

- Shoulder milling
- KAPR = 90°
- Internal coolant
- Economical double-sided system
- Long effective cutting edge
- Reliable and versatile system
- Stable, reliable and easy insert positioning

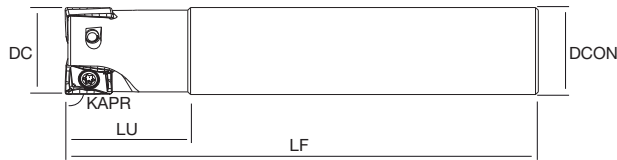

CYLINDRICAL

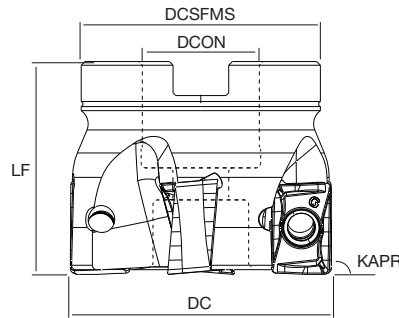

ARBOR



| | Designation | Stock | DC | ZEFP | DCON | DCSFMS | LF | LU | WT | MIID | | |
|-----------------------|-----------------------|-------|-----|------|------|--------|-----|-----|----------|----------|--|--|
| CYLINDRICAL | NT-DRK17 D032-S32-Z02 | ● | 32 | 2 | 32 | | 130 | 45 | 0.8 | NT-DRK17 | | |
| | NT-DRK17 D040-S32-Z03 | ● | 40 | 3 | 32 | | 150 | 40 | 1.1 | NT-DRK17 | | |
| | | | | | | | | | | | | |
| ARBOR | NT-DRK17 D050-F22-Z04 | ● | 50 | 4 | 22 | 45 | 40 | | 0.4 | NT-DRK17 | | |
| | NT-DRK17 D063-F22-Z05 | ● | 63 | 5 | 22 | 55 | 40 | | 0.7 | NT-DRK17 | | |
| | NT-DRK17 D063-F22-Z06 | ● | 63 | 6 | 22 | 55 | 40 | | 0.7 | NT-DRK17 | | |
| | NT-DRK17 D080-F27-Z06 | ● | 80 | 6 | 27 | 60 | 50 | | 1.3 | NT-DRK17 | | |
| | NT-DRK17 D080-F27-Z07 | ● | 80 | 7 | 27 | 60 | 50 | | 1.3 | NT-DRK17 | | |
| | NT-DRK17 D100-F32-Z07 | ● | 100 | 7 | 32 | 78 | 50 | | 1.9 | NT-DRK17 | | |
| | NT-DRK17 D100-F32-Z09 | ● | 100 | 9 | 32 | 78 | 50 | | 1.9 | NT-DRK17 | | |
| | NT-DRK17 D125-F40-Z08 | ● | 125 | 8 | 40 | 80 | 63 | | 2.9 | NT-DRK17 | | |
| NT-DRK17 D125-F40-Z10 | ● | 125 | 10 | 40 | 80 | 63 | | 2.9 | NT-DRK17 | | | |

| | | |
|-------------|---|---|
| Spare Parts | INSERT SCREW | INSERT WRENCH |
| |  |  |

| | | |
|---------------|----------|----------|
| NT-DRK17 D□□□ | NT-ST037 | NT-FTB15 |
|---------------|----------|----------|



**large contact surfaces
for stable and reliable operation**

www.nikkotools.com



Via Don F. Tosatto, 8
30174 Mestre - Venezia
+39 041.959179
info@nikkotools.com



\$NKDEP21DRK